

# Materials for 3D provisional restorations

## Comparison of their physical and mechanical properties with CAD-CAM and conventional temporary restorations, literature review

UPDATE

### Materiales para restauraciones provisionales 3D

Comparativa de sus propiedades físicas y mecánicas frente a restauraciones temporarias cad-cam y convencionales, revisión de literatura

### Materiais para Restaurações Provisórias 3D

Comparação de suas propriedades físicas e mecânicas com restaurações temporárias CAD-CAM e convencionais, revisão da literatura

#### Abstract.

Recent advances in digital design and additive manufacturing, or three-dimensional printing, have enabled the development of various dental materials with multiple clinical applications. Among these numerous uses, the fabrication of three-dimensional printing provisional restorations has gained significant popularity in recent years. Therefore, it is desirable that the materials employed in the production of these restorations exhibit suitable physical and mechanical properties; allowing them to effectively fulfill their intended function. This study aims to conduct a literature review on the physical properties (color stability and water sorption) and mechanical properties (compressive strength, flexural strength, wear resistance, hardness), of materials for three-dimensional printing provisional restorations and compare them with materials for provisional restorations obtained through computer-aided design and manufacturing, CAD-CAM, and the traditional method. To this end, a search was conducted in various databases, including the BVS, PubMed, and Google Scholar, with publication dates ranging from 2019 to 2024. Additionally, references from the obtained articles were also included. Eligibility criteria were established to guide the selection. It was established that three-dimensional printing materials, when compared with provisional restoration materials obtained through CAD-CAM and traditional methods, present limitations in their physical and mechanical properties. Nevertheless, the short-term use of provisional restorations manufactured with three-dimensional printing technology may be considered an alternative to those obtained through CAD-CAM and traditional methods.

AUTHOR

 Gastón Olascuaga Wirgman<sup>1</sup>

<sup>1</sup> Prof. Adj. Departamento de Odontología preventiva y restauradora, sub unidad académica Operatoria Dental I, Facultad de Odontología, Universidad de la República.

CORRESPONDENCE

Gastón Olascuaga Wirgman  
[golascu@gmail.com](mailto:golascu@gmail.com)

Received: December 27, 2024  
Accepted: August 15, 2025



**Keywords:** Provisional restorations, 3D printing, additive manufacturing, properties.

## Resumen.

Los avances en el diseño digital y manufactura aditiva, o impresión tridimensional, han permitido el desarrollo de diversos materiales dentales con múltiples aplicaciones clínicas. Dentro de estos muchos usos, la confección de restauraciones provisionales realizadas mediante impresión tridimensional ha cobrado gran popularidad en los últimos años. Por lo tanto, es deseable que los materiales utilizados en la fabricación de dichas restauraciones presenten adecuadas propiedades físicas y mecánicas, que les permitan cumplir eficazmente con la función para la cual fueron diseñados. El objetivo de este trabajo es, realizar un análisis de la literatura en cuanto a las propiedades físicas (estabilidad de color y sorción acuosa) y mecánicas (resistencia compresiva, resistencia flexural, resistencia al desgaste, dureza), de los materiales utilizados en la confección de restauraciones provisionales obtenidas mediante impresión tridimensional y compararlas con aquellos materiales para provisionales obtenidos mediante el método de diseño y manufactura asistido por computador, cad-cam, y el método tradicional. Para tal fin se realizó una búsqueda en diferentes bases de datos como, la Biblioteca Virtual en Salud Odontología, Pubmed y Google scholar, con un rango de fechas de publicación desde el año 2019 al 2024. A su vez se incorporaron también aquellas publicaciones que surgieron como referencias de los diferentes artículos obtenidos. Se estableció un criterio de elegibilidad que permitió guiar la selección. En este trabajo se pudo establecer que los materiales para impresión tridimensional al ser comparados con materiales para provisionales obtenidos mediante técnica cad-cam y método tradicional presentan limitaciones en sus propiedades físicas y mecánicas. De todas formas, la utilización en el corto plazo de restauraciones provisionales elaboradas mediante tecnología de impresión tridimensional puede ser considerado como una alternativa al uso de provisionales confeccionados mediante cad-cam y el método tradicional.

**Palabras clave:** provisionales, impresión 3D, manufactura por adición, propiedades.

## Resumo.

Os recentes avanços no design digital e na manufatura aditiva, ou impressão tridimensional, permitiram o desenvolvimento de diversos materiais dentários com múltiplas aplicações clínicas. Entre esses inúmeros usos, a confecção de restaurações provisórias realizadas por meio de impressão tridimensional ganhou grande popularidade nos últimos anos. Portanto, é desejável que os materiais utilizados na fabricação dessas restaurações exibam boas propriedades físicas e mecânicas para cumprir a função para a qual foram criados. O objetivo deste trabalho é estudar as propriedades físicas (cor-absorção de água) e mecânicas (resistência à compressão, resistência à flexão, resistência ao desgaste, dureza) dos materiais para restaurações provisórias obtidas por impressão tridimensional e compará-los com os materiais para provisionais obtidos pelo método de design e manufatura assistidos por computador, cad-cam e o método tradicional. Para isso, foi realizada uma busca em diversas bases de dados, como a Biblioteca Virtual em Saúde Odontológica, PubMed e Google Scholar, com um intervalo de datas de publicação de 2019 a 2024. Também foram incluídas as publicações que surgiram como referências dos artigos obtidos. Foi estabelecido um critério de elegibilidade para orientar a seleção. Dentre as limitações deste trabalho, foi possível concluir que os materiais para impressão tridimensional quando comparados com os materiais para provisionais cad-cam e método tradicional, apresentam limitações em suas propriedades físicas, mas apresentam resultados adequados em suas propriedades mecânicas. As restaurações provisórias feitas por meio da tecnologia de impressão tridimensional devem ser consideradas uma alternativa às feitas por cad-cam e método tradicional.

**Palavras-chave:** Provisórios, impressão 3D, manufatura aditiva, propriedades.

## Introduction

Obtaining a high-quality definitive restoration largely depends on the fabrication and placement of a correctly designed provisional restoration. The provisional restoration should maintain the position of the tooth in the dental arch, protect the dentin-pulp complex, preserve periodontal health, and restore lost function and esthetics. In addition, the use of provisional restorations should be considered a key element in diagnosis and treatment planning. <sup>(1-2-3-4)</sup>

The clinical indications for provisional restorations are varied, ranging from partial coronal restorations to extensive oral rehabilitations. In many cases, these restorations may remain functional for extended periods of time. Therefore, they must exhibit adequate physical and mechanical properties <sup>(1)</sup>.

Accordingly, this type of intermediate or provisional restoration should present proper color stability, low water sorption, high wear resistance and surface hardness, as well as adequate flexural and compressive strength values <sup>(5-6)</sup>.

According to their composition, materials for provisional restorations can be classified into two main groups: those based on acrylic resins such as polymeth-

yl methacrylate (PMMA) or polyethyl methacrylate (PEMA), and those composed of bis-acrylates/resins (bisphenol A-glycidyl methacrylate, urethane dimethacrylate) <sup>(7)</sup>.

For many years, these materials have been used in the conventional fabrication of provisional restorations, both directly and indirectly. Currently, they continue to be used with certain modifications in their formulation, both in fabrication by computer-aided design and manufacturing, CAD-CAM, (CC) and in the fabrication of restorations through three-dimensional (3D) printing (**Figure 1**). However, it is worth noting that the chemical composition of many 3D printing materials remains proprietary, and therefore little information is provided by manufacturers <sup>(8)</sup>.

The emergence of CC has enabled the development of provisional restorations produced by mechanical milling (a subtractive manufacturing technique). This process consists of computer-assisted milling of pre-polymerized resin blocks to obtain a provisional restoration that, when compared with those fabricated by conventional techniques, shows improved physical and mechanical properties, while also overcoming disadvantages such as high polymerization shrinkage and increased levels of residual monomers <sup>(5)</sup>.

Recently, additive manufacturing techniques, or 3D printing, have been gaining popularity. These techniques consist of the successive addition of thin layers of light-curing resin to shape the desired object. Among the different 3D printing methods (**Figure 2, Figure 3**) are stereolithography (SLA), digital light processing (DLP), selective laser sintering (SLS), and fused deposition modeling (FDM) <sup>(9)</sup>.

In contrast to the CC technique, 3D printing has demonstrated significant savings in material and time during the fabrication of provisional restorations. Although 3D printing materials present poor physical properties –when compared with CC and traditional methods (TM)-- several authors report that they exhibit better mechanical properties and greater accuracy in the fit of restorations compared with those obtained by conventional methods <sup>(10-11)</sup>. Therefore, they should be considered a good alternative to the CC method and the traditional method (TM) <sup>(8)</sup>.

This study aims to describe the characteristics and properties of materials for provisional restorations fabricated by 3D printing, and to compare the physical (color stability, water sorption) and mechanical (compressive strength, flexural strength, wear resistance, hardness) properties of 3D printed resins with those of resins used in CC and TM procedures.



**Figure 1.** 3D Printer

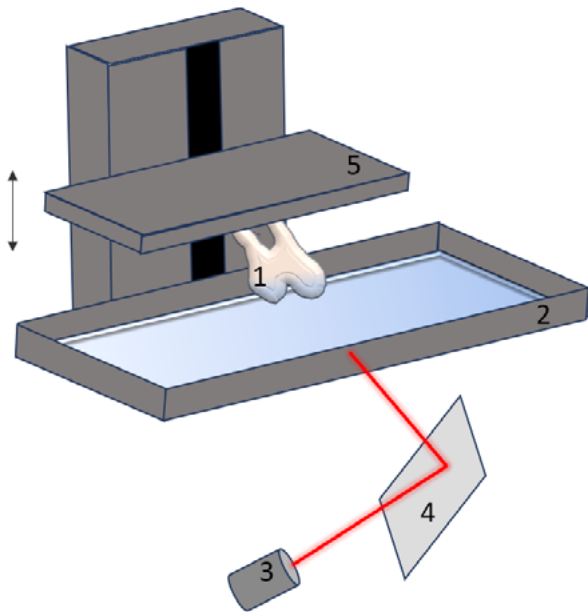

**Figure 2**  
Stereolithography printing technology

**SLA**

1. Printed specimen
2. Resin cradle
3. Laser
4. Mirror
5. Build platform

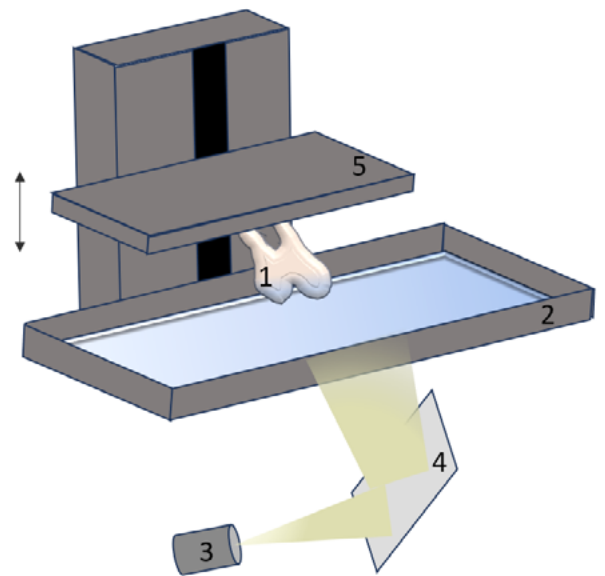

**Figure 3**  
Digital Light Processing printing technology

**DLP**

1. Printed specimen
2. Resin cradle
3. LED light emitter
4. Mirror
5. Build platform

## Methods

To meet the objectives set for 2024, a narrative literature review was conducted. Databases consulted included the Virtual Health Library in Dentistry, PubMed, and Google Scholar, with a date range between 2019 and 2024 (given the relatively recent nature of the technology, earlier evidence is scarce). Filters were applied for language (English) and for publications meeting the requirements of randomized controlled trials, reviews, systematic reviews, meta-analyses, and clinical trials. Additionally, publications referenced in the retrieved records were also traced through manual searching.

A search was carried out using the following combination of English descriptors: “provisional” AND “3D printing” OR “three-dimensional printing” OR “additive manufacturing” AND “properties.”

Initially, publications matching the proposed study topic were selected by their title, abstract, and conclusions. Eligibility and exclusion criteria were established. The selected publications were then subjected to full-text assessment, which determined the final selection included in this study.

### INCLUSION CRITERIA

- Clinical research
  - » In vitro research
- Evaluation of the properties of 3D provisional restoration materials
  - » Studies comparing the physical properties of provisional restorations obtained by different fabrication methods
  - » Studies comparing the mechanical properties of provisional restorations obtained by different fabrication methods.

### EXCLUSION CRITERIA

- » Studies comparing properties other than physical and mechanical
- » Literature not published in English

A total of 1407 general records were obtained from the databases based on the combination of the previously mentioned descriptors and established filters. An additional 10 records were retrieved through manual search. After reading their titles and abstracts, 1210 records were excluded and 43 were identified as duplicates; therefore, 154 records were selected. In a third stage, and according to the pre-established eligibility criteria, 93 records were selected for full-text reading, of which 27 were included in this review. Those identified by manual search were also included, resulting in a total of 37 records incorporated into this review (Figure 4).

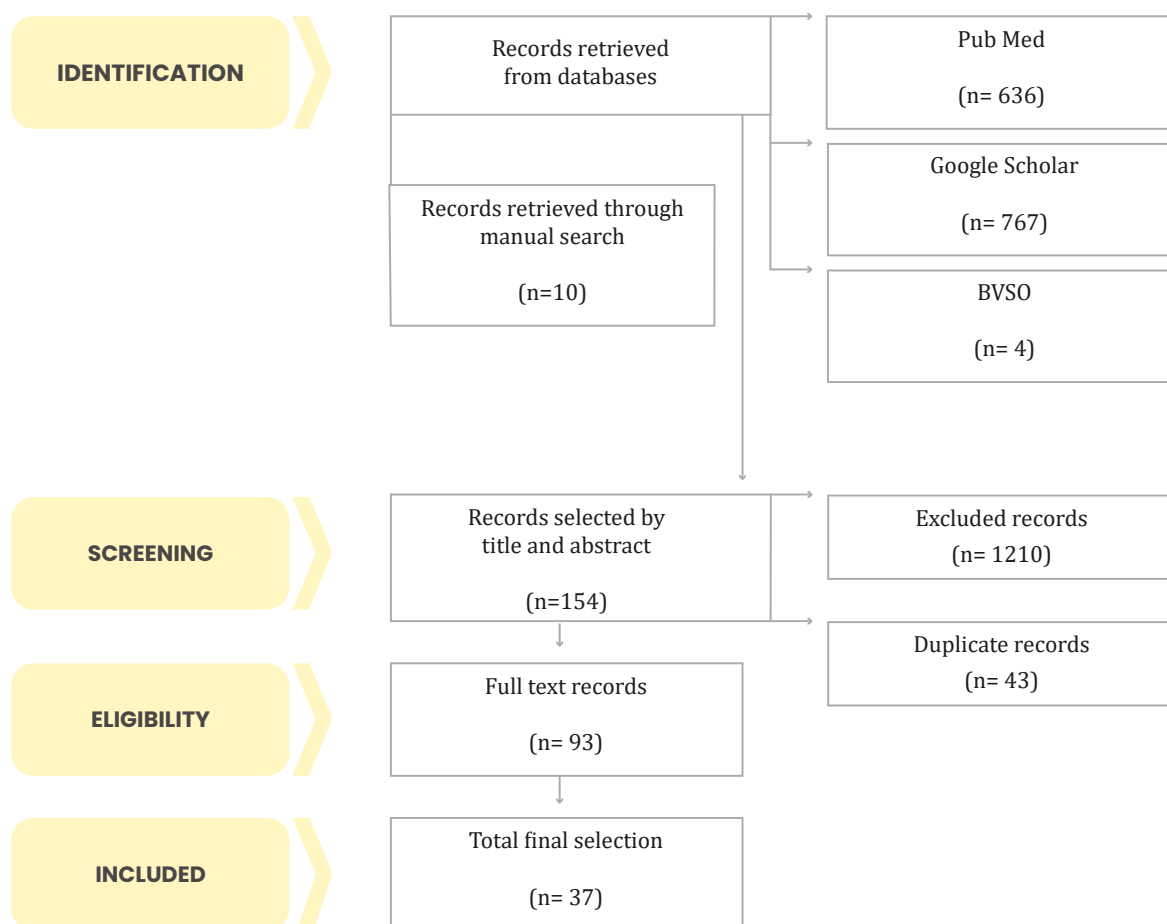

Figure 4. Flow diagram

## Development

Although there are similar studies comparing the different properties of materials for provisional restorations<sup>(1,2,3,5,8)</sup>, it is necessary to continue research on this subject given the novelty of the technology and the constant emergence and development of new materials and techniques. For this reason, the present work aims to further explore and highlight different aspects of the topic under study.

### PHYSICAL PROPERTIES

Among the different properties of materials for provisional restorations, their esthetic stability is of particular relevance. This is especially important for provisional restorations that, for various reasons, must remain in function for extended periods of time. From an esthetic perspective, provisional restorations should exhibit a quality comparable to that of natural teeth<sup>(1)</sup>.

To achieve this, factors such as the fabrication technique of the provisional restoration, the material used, and other influencing variables—including the water sorption and solubility of the material—must be considered<sup>(12)</sup>.

The poor color stability observed in provisional restorations obtained by 3D printing has a multifactorial origin. On the one hand, analysis of the material reveals that resins produced through 3D printing present a lower degree of polymerization due to reduced crosslinking of polymer chains, resulting in a less dense material (unlike those obtained through CC and TM). This leads to low color stability, a drawback that persists even when adequate post-curing procedures are applied<sup>(13-14-15)</sup>. A low polymerization rate and the high presence of residual monomers result in poor mechanical and biological properties, associated with an increased likelihood of discoloration and therefore esthetic alterations of the provisional restoration<sup>(15)</sup>.

When studying different provisional materials, it is observed that PMMA-based materials used in CC and TM include hydrophobic monomers such as methyl methacrylate (MMA). In contrast, the light-polymerized resins used in 3D printing contain hydrophilic monomers such as HEDMA<sup>(16)</sup>. According to Berli<sup>(17)</sup> and Shin<sup>(12)</sup>, this may explain the greater water sorption observed in resins for 3D-printed provisional restorations, which negatively affects the optical stability of the restoration. Moreover, it should be noted that 3D-printed restorations are fabricated layer by layer, allowing water or other substances in contact with the material to infiltrate between the

layers, altering polymer chains and affecting both physical (color stability and water sorption) and mechanical properties<sup>(17-18)</sup>.

Finally, studies by Atria<sup>(15)</sup> relate the poor color stability of 3D-printed resins to the lack of filler particles in these materials, while Song<sup>(19)</sup> attributes the poor physical performance of these materials to the presence of a final layer of unpolymerized monomers.

### MECHANICAL PROPERTIES

As with conventional composite resins, multiple factors can influence the mechanical performance of 3D-printed materials (compressive strength, flexural strength, wear resistance, hardness). Examples include filler particle size and shape, monomer type, viscosity, and flowability, among others. In addition, there are intrinsic characteristics of these materials such as the type of printer used, polymerization time, light source of the printer, and post-curing procedures<sup>(20)</sup>. Furthermore, the orientation of printing (**Figure 5**) should be considered as an influential factor in the final mechanical properties of the material, the accuracy of the print, and the surface characteristics of the finished restoration. By varying the printing orientation, the light beam must pass through different thicknesses of material, which influences the degree of polymerization, thereby affecting the mechanical performance of the material and the finished restoration<sup>(21)</sup>. Alharbi et al.<sup>(10)</sup> reported that higher compressive strength values of 3D resins are obtained when the printing direction is perpendicular to the surface that will receive the load. It is also important to consider the effect of resin layer thickness in 3D restorations. Diverse studies<sup>(14,22)</sup> emphasize that the thinner the layer, the better the polymerization, and consequently, the better the final properties of the material.

In turn, Al-Dulaijan et al.<sup>(23)</sup> concluded that proper post-curing procedures are essential for 3D-printed materials. This involves cleaning (often with isopropyl alcohol), followed by additional photopolymerization, thereby achieving a higher degree of monomer-to-polymer conversion (leaving fewer residual monomers), which considerably improves the flexural strength of the material.

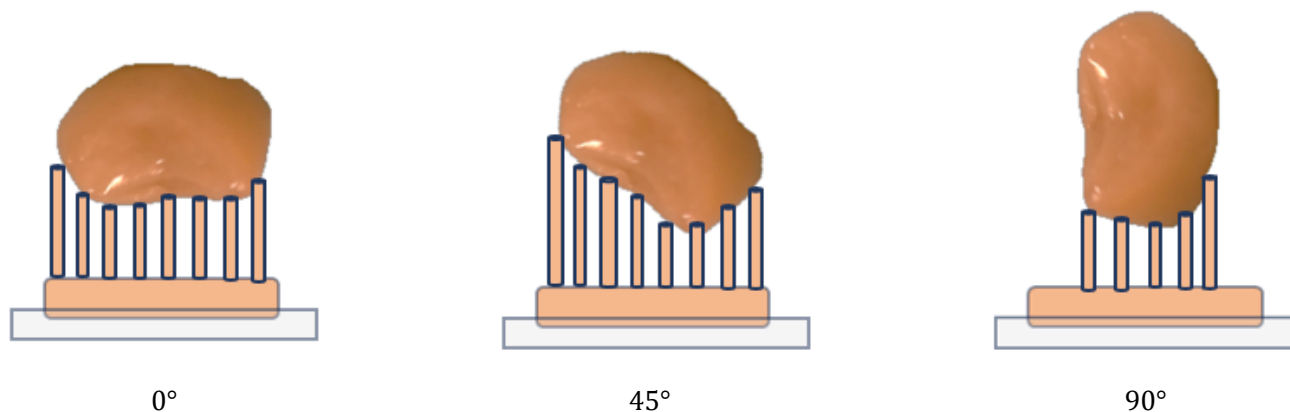

**Figure 5.** Different printing angles.

## Discussion

From the study of the physical properties of provisional restorations obtained through 3D printing, it can be inferred that, regardless of the composition of the material or the printing technology used, these restorations exhibit inferior results compared to provisional restorations obtained through CC or TM.<sup>(1)</sup>

Song et al.<sup>(19)</sup> concluded in their studies that the color stability of PMMA resins for 3D-printed provisional restorations is lower compared to those obtained by CC and TM, showing greater instability over time and poorer short- and medium-term results. The differences are particularly evident when compared to CC restorations.

In line with this, Shin et al.<sup>(12)</sup>, when studying different resin blocks obtained by 3D, CC, and TM that were immersed and stored in different substances (distilled water, coffee, grape juice, and curry) and for varying periods of time (up to 30 days), observed that the degree of discoloration is directly related to the material used and the storage time in the staining solution. Among the materials evaluated, the resins obtained through 3D printing showed noticeable color changes even after short periods of immersion (in all substances evaluated). Compared to the blocks obtained by CC, the 3D resins exhibited poor color stability.<sup>(12)</sup>

Similarly, Atria et al.<sup>(15)</sup> and Taşın et al.<sup>(16)</sup>, when studying the color stability of hybrid resins for 3D printing and comparing them with PMMA resins obtained by the CC method, observed that 3D-printed resins exhibited low color stability over time. In contrast, they found

greater color stability in hybrid resins obtained by 3D printing compared to PMMA and bis-acrylic resins obtained by TM.

Song et al.<sup>(19)</sup> studied the color stability of resins for provisional restorations obtained by 3D printing, CAD-CAM, and TM. The samples of this in-vitro study were immersed and stored for 12 weeks in coffee and tea solutions. The authors concluded that regardless of the material or staining solution, all samples showed a statistically significant color change. Samples obtained by CC and 3D printing technology exhibited greater color change after 8 weeks compared to resins obtained by TM.

Kim et al.<sup>(24)</sup> evaluated the color stability and translucency over time of five different types of 3D printing resins. The samples were fabricated using DLP technology and stored in distilled water (at 37 °C and in the dark) for periods ranging from 1 day to 6 months. The results of this in vitro study showed that after one month, some samples exhibited perceptible color changes while others did not, and no changes in translucency were found. After 6 months, all samples showed noticeable color changes and slight changes in translucency. In conclusion, the authors reported that after 6 months the color of all tested 3D printing resins changed, becoming darker, more yellow, and more opaque. The extent of the change depended on the resin used, whereas changes in translucency across all materials studied were limited.

## MECHANICAL PROPERTIES

A recent systematic review<sup>(1)</sup>, in which different mechanical properties of 3D resins were studied and compared with resins obtained by CC and TM, showed that 3D-printed restorations (unlike what occurs with physical properties) achieve better results in some of these properties.

Alzaharani et al.<sup>(25)</sup> identified different factors that can influence the mechanical properties of 3D resins, such as the thickness of the printed resin layer, the type of post-curing treatment, polymerization shrinkage between layers, the time and intensity of photopolymerization, and the printing direction. Alharbi et al.<sup>(10)</sup> reported that the compressive strength of 3D resins increases considerably when the printing angle is changed (between 0°, 45°, and 90°).

The highest compressive strength values are achieved when 3D resins are printed perpendicular to the direction in which the load will be applied (**Figure 6**). Derban et al.<sup>(26)</sup> stated that flexural strength is one of the main factors influencing the mechanical behavior of this type of restoration. In this regard, their in vitro studies concluded that the printing angle has a significant effect on flexural strength, with better values achieved at 90° and 0° angles and poorer results at 45°<sup>(26)</sup>. Several studies<sup>(27-28)</sup> have evaluated the flexural strength of provisional restorations fabricated by 3D, CC, and TM methods. These studies agree that CC res-

torations exhibit greater flexural strength compared to those obtained by TM and 3D. This can be partly explained by the fact that resins used in the CC technique (unlike those used in 3D and TM) are denser materials, with lower porosity and less presence of free monomers in their composition.

Aati et al.<sup>(29)</sup> found that better flexural strength values in restorations obtained by 3D printing can be achieved when zirconium oxide nanoparticles are added to the printing material. Wear resistance is another factor that has a great influence on the long-term functionality of provisional restorations<sup>(30)</sup>.

In vitro studies by Myagmar et al.<sup>(31)</sup> showed greater wear resistance (after subjecting samples to repeated masticatory cycles) and a smoother surface in specimens obtained through 3D and CAD-CAM techniques compared with those obtained by the TM method. Furthermore, Park et al.<sup>(32)</sup> concluded that 3D printing resins present wear values similar to those obtained by TM. The authors interpreted the differences among studies as being due to variations in printing technology and post-curing methods used (**Figure 7**).

Kessler et al.<sup>(30)</sup> compared the wear resistance of different resinous materials obtained by 3D, CC, and a direct-applied composite technology. The authors concluded that, within the limitations of their in vitro study, the wear resistance values of resins obtained by 3D technology are similar to those obtained by CC.

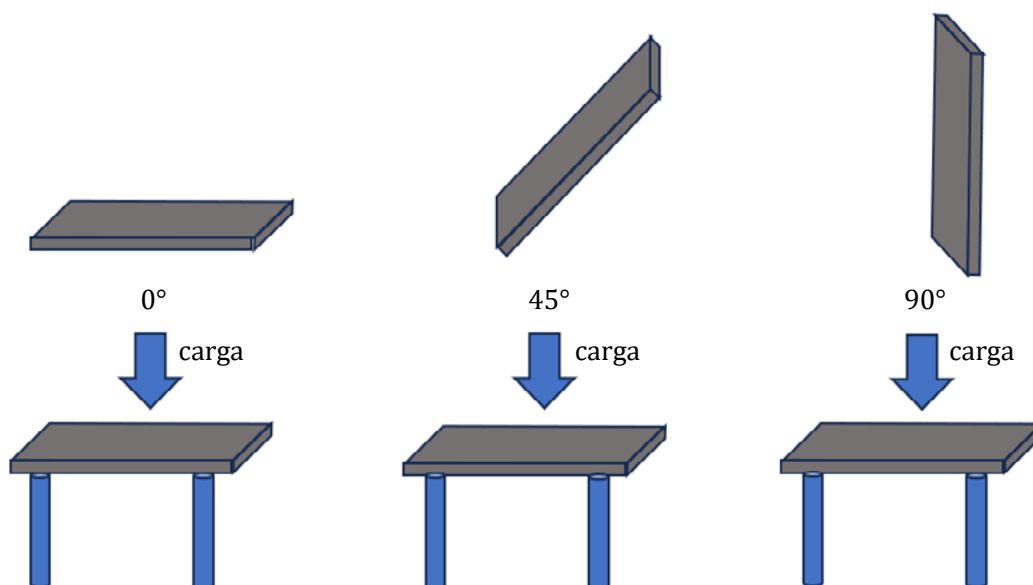

**Figure 6.** Load application on printed specimens with different angulation.

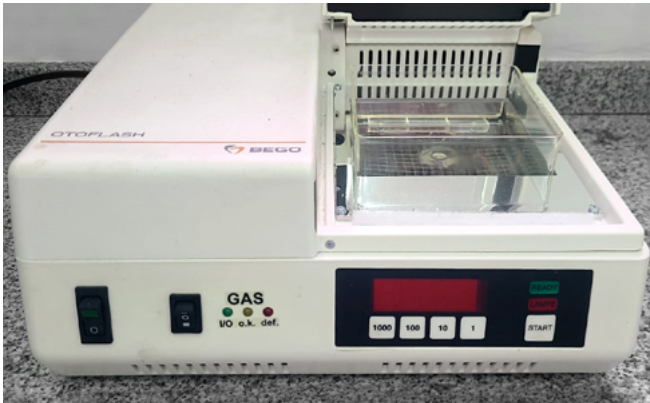

**Figure 7.** 3D resin post-curing unit.

They also established that materials with lower wear rates are those with higher filler content in their composition. In this case, the direct-applied composite (Bis-GMA) and one of the 3D printing resins (UDMA) showed the best results. Therefore, the authors recommend the use of resins with a high filler index in their composition.

## Conclusions

Despite the limitations of this work, such as the scarce existing clinical evidence and the lack of medium- and long-term in vivo studies, it can be concluded that:

- The materials used for the fabrication of provisional restorations by 3D printing exhibit poor color stability and higher water absorption when compared with those produced by CC and TM, leading to restorations that become darker, more yellow, and more opaque over time.
- 3D printed materials exhibit flexural strength values comparable to, and in some cases higher than, those obtained by CC and TM. In terms of wear resistance, 3D printed materials present similar or even better values than those obtained with CC and TM.
- The angle at which 3D printing is performed can increase or decrease the compressive and flexural strength of resin materials.
- Materials for provisional restorations obtained by CC achieve better hardness values compared to 3D and TM restorations.
- The physical and mechanical properties of materials used in the fabrication of 3D provisional restorations can vary greatly depending on the printing technology used, polymerization time, printing angle, material composition, and post-curing techniques and processes.
- The use of 3D provisional restorations for short periods of time (especially in the esthetic sector) can be considered as an alternative to materials produced by CC and TM methods.

Hardness could be considered an indicator of the density of the material, and therefore it could be hypothesized that higher density corresponds to greater wear resistance and lower surface deterioration<sup>(33)</sup>. However, hardness alone cannot be used as an indicator of rigidity or overall resistance of the material, and thus this property by itself cannot be considered a predictor of the long-term mechanical behavior of restorations<sup>(34)</sup>.

Souza et al.<sup>(35)</sup> and Perea-Lowery et al.<sup>(36)</sup>, when studying the Vickers hardness of resinous materials obtained by 3D and CC methods, observed better performance in materials obtained by the CC method. The authors explained these results by noting that materials used in the CC manufacturing method are denser and therefore present less internal porosity.

Simoneti et al.<sup>(37)</sup>, in an in vitro study, compared the Vickers hardness of resinous provisional materials obtained by 3D printing and those obtained by TM using PMMA and bis-acrylic resins. They concluded that samples fabricated by TM using PMMA achieved the highest Vickers hardness values, while similar values were observed between samples obtained by the 3D printing method and bis-acrylic TM resins.

## REFERENCES

1. Jain S, Sayed ME, Shetty M, Alqahtani SM, al Wadei MHD, Gupta SG, et al. Physical and Mechanical Properties of 3D-Printed Provisional Crowns and Fixed Dental Prosthesis Resins Compared to CAD/CAM Milled and Conventional Provisional Resins: A Systematic Review and Meta-Analysis. Vol. 14, *Polymers*. MDPI; 2022.
2. Al Wadei MHD, Sayed ME, Jain S, Aggarwal A, Alqarni H, Gupta SG, et al. Marginal Adaptation and Internal Fit of 3D-Printed Provisional Crowns and Fixed Dental Prosthesis Resins Compared to CAD/CAM-Milled and Conventional Provisional Resins: A Systematic Review and Meta-Analysis. Vol. 12, *Coatings*. MDPI; 2022.
3. Alt, V.; Hanning, M.; Wostmann, B.; Balkenhol, M. Fracture strength of temporary fixed partial dentures: CAD/CA versus directly fabricated restorations. *Dent. Mater.* 2001, 27, 339–347.
4. Gratton, D.G.; Aquilino, S.A. Interim restorations. *Dent. Clin. N. Am.* 2004, 48, 487–497.
5. Taşın, S.; Ismatullaev, A. Comparative evaluation of the effect of thermocycling on the mechanical properties of conventionally polymerized, CAD-CAM milled, and 3D-printed interim materials. *J. Prosthet. Dent.* 2022, 127, 173.e1–173.e8.
6. Revilla-León, M.; Meyers, M.J.; Zandinejad, A.; Özcan, M. A review on chemical composition, mechanical properties, and manufacturing workflow of additively manufactured current polymers for interim dental restorations. *J. Esthet. Restor. Dent.* 2019, 31, 51–57.
7. Burns, D.R.; Beck, D.A.; Nelson, S.K. A review of selected dental literature on contemporary provisional fixed prosthodontic treatment: Report of the committee on research in fixed prosthodontics of the academy of fixed prosthodontics. *J. Prosthet. Dent.* 2003, 90, 474–497.
8. Pantea M, Ciocoiu RC, Greabu M, Totan AR, Imre M, Țâncu AMC, et al. Compressive and Flexural Strength of 3D-Printed and Conventional Resins Designated for Interim Fixed Dental Prostheses: An In Vitro Comparison. *Materials*. 2022 May 1;15(9).
9. Tian Y, Chen CX, Xu X, Wang J, Hou X, Li K, et al. A Review of 3D Printing in Dentistry: Technologies, Affecting Factors, and Applications. Vol. 2021, *Scanning*. Hindawi Limited; 2021.
10. Alharbi, N.; Osman, R.; Wismeijer, D. Effects of build direction on the mechanical properties of 3D-printed complete coverage interim dental restorations. *J. Prosthet. Dent.* 2016, 115, 760–767.
11. Alharbi, N.; Osman, R.B.; Wismeijer, D. Factors Influencing the Dimensional Accuracy of 3D-Printed Full-Coverage Dental Restorations Using Stereolithography Technology. *Int. J. Prosthodont.* 2016, 29, 503–510.
12. Shin JW, Kim JE, Choi YJ, Shin SH, Nam NE, Shim JS, et al. Evaluation of the color stability of 3d-printed crown and bridge materials against various sources of discoloration: An in vitro study. *Materials*. 2020 Dec 1;13(23):1–13.
13. Jain, S.; Sayed, M.; Ahmed, W.M.; Halawi, A.H.A.; Najmi, N.M.A.; Aggarwal, A.; Bhandi, S.; Patil, S. An in-vitro study to evaluate the effect of denture cleansing agents on color stability of denture bases fabricated using CAD/CAM milling, 3D-printing and conventional techniques. *Coatings* 2021, 11, 962.
14. Tahayeri, A.; Morgan, M.; Fugolin, A.P.; Bompolaki, D.; Athirasala, A.; Pfeifer, C.S.; Ferracane, J.L.; Bertassoni, L.E. 3D printed versus conventionally cured provisional crown and bridge dental materials. *Dent. Mater.* 2018, 34, 192–200.
15. Atria, P.J.; Lagos, I.; Sampaio, C.S. In vitro evaluation of surface roughness, color stability, and color masking of provisional restoration materials for veneers and crowns. *Int. J. Comput. Dent.* 2020, 23, 343–350.

16. Taşın S, Ismatullaev A, Usumez A. Comparison of surface roughness and color stainability of 3-dimensionally printed interim prosthodontic material with conventionally fabricated and CAD-CAM milled materials. *J Prosthet Dent [Internet]*. 2022;128(5):1094–101.
17. Berli, C.; Thieringer, F.M.; Sharma, N.; Müller, J.A.; Dedem, P.; Fischer, J.; Rohr, N. Comparing the mechanical properties of pressed, milled, and 3D-printed resins for occlusal devices. *J. Prosthet. Dent.* 2020, 124, 780–786.
18. Gad, M.M.; Fouda, S.M.; Abualsaud, R.; Alshahrani, F.A.; Al-Thobity, A.M.; Khan, S.Q.; Akhtar, S.; Ateeq, I.S.; Helal, M.A.; Al-Harbi, F.A.; et al. Strength and surface properties of a 3D-printed denture base polymer. *J. Prosthodont.* 2021, 31, 412–418.
19. Song, S.-Y.; Shin, Y.-H.; Lee, J.-Y.; Shin, S.-W. Color stability of provisional restorative materials with different fabrication methods. *J. Adv. Prosthodont.* 2020, 12, 259–264.
20. Atria PJ, Bordin D, Marti F, Nayak VV, Conejo J, Benalcázar Jalkh E, et al. 3D-printed resins for provisional dental restorations: Comparison of mechanical and biological properties. *J Esthet Restor Dent [Internet]*. 2022;34(5):804–15.
21. Tahayeri A, Morgan MC, Fugolin AP, et al. 3D printed versus conventionally cured provisional crown and bridge dental materials. *Dent Mater.* 2018;34:192-200.
22. Ibrahim, A.; Shehawy, D.E.; El-Naggar, G. Fracture resistance of interim restoration constructed by 3D printing versus CAD/CAM technique (in vitro study). *Ain Shams Dent. J.* 2020, 23, 13–20.
23. Al-Dulaijan YA, Alsulaimi L, Alotaibi R, Alboainain A, Akhtar S, Khan SQ, et al. Effect of printing orientation and postcuring time on the flexural strength of 3D-printed resins. *J Prosthodont.* 2023;32(S1):45–52.
24. Kim J-E, Choi W-H, Lee D, Shin Y, Park S-H, Roh B-D, et al. Color and translucency stability of three-dimensional printable dental materials for crown and bridge restorations. *Materials (Basel).* 2021;14(3):650.
25. Alzahrani SJ, Hajjaj MS, Azhari AA, Ahmed WM, Yeslam HE, Carvalho RM. Mechanical Properties of three-dimensional Printed Provisional Resin Materials for crown and fixed dental prosthesis: A systematic review. *Bioengineering (Basel).* 2023;10(6).
26. Derban P, Negrea R, Rominu M, Marsavina L. Influence of the printing angle and load direction on flexure strength in 3D printed materials for provisional dental restorations. *Materials (Basel).* 2021;14(12):3376.
27. Ellakany, P.; Fouda, S.M.; Mahrous, A.A.; AlGhamdi, M.A.; Aly, N.M. Influence of CAD/CAM milling and 3d-printing fabrication methods on the mechanical properties of 3-unit interim fixed dental prosthesis after thermo-mechanical aging process. *Polymers* 2022, 14, 4103.
28. Turksayar, A.A.D.; Donmez, M.B.; Olcay, E.O.; Demirel, M.; Demir, E. Effect of printing orientation on the fracture strength of additively manufactured 3-unit interim fixed dental prostheses after aging. *J. Dent.* 2022, 124, 104155.
29. Aati S, Akram Z, Ngo H, Fawzy AS. Development of 3D printed resin reinforced with modified ZrO<sub>2</sub> nanoparticles for long-term provisional dental restorations. *Dent Mater.* 2021;37(6):e360–74.
30. Kessler A, Reymus M, Hickel R, Kunzelmann K-H. Three-body wear of 3D printed temporary materials. *Dent Mater.* 2019;35(12):1805–12.
31. Myagmar G, Lee J-H, Ahn J-S, Yeo I-SL, Yoon H-I, Han J-S. Wear of 3D printed and CAD/CAM milled interim resin materials after chewing simulation. *J Adv Prosthodont [Internet]*. 2021;13(3):144–51.

32. Park JM, Ahn JS, Cha HS, Lee JH. Wear resistance of 3D printing resin material opposing zirconia and metal antagonists. *Materials (Basel)* 2018;11:1043.
33. Digholkar S, Madhav VN, Palaskar J. Evaluation of the flexural strength and microhardness of provisional crown and bridge materials fabricated by different methods. *J Indian Prosthodont Soc.* 2016 Oct-Dec;16(4):328-34.
34. Diaz-Arnold AM, Dunne JT, Jones AH. Microhardness of provisional fixed prosthodontic materials. *J Prosthet Dent.* 1999 Nov;82(5):525-8.
35. Souza ALC, de Oliveira Cruvinel Filho JL, da Rocha SS. Flexural strength and Vickers hardness of milled and 3D-printed resins for provisional dental restorations. *Brazilian Journal of Oral Sciences.* 2022;22.
36. Perea-Lowery L, Gibreel M, Vallittu PK, Lassila L. Evaluation of the mechanical properties and degree of conversion of 3D printed splint material. *J Mech Behav Biomed Mater.* 2021;115(104254):104254.
37. Simoneti DM, Pereira-Cenci T, Dos Santos MBF. Comparison of material properties and biofilm formation in interim single crowns obtained by 3D printing and conventional methods. *J Prosthet Dent.* 2022;127(1):168-72.

## Data availability

The entire dataset supporting the results of this study has been published in the article itself.

## Conflict of Interest

The author declares no conflict of interest.

## Funding source

This research did not receive any specific funding from agencies in the public, commercial, nor nonprofit sector.

## Authorship Contribution

AUTHORS' FULL NAME	ACADEMIC COLLABORATION													
	1	2	3	4	5	6	7	8	9	10	11	12	13	14
Gastón Olascuaga Wirgman	x		x	x	x	x	x	x	x	x	x	x	x	x

- |                                 |  |
|---------------------------------|--|
| 1. Project Administration       | 8. Methodology                           |
| 2. Funding Acquisition          | 9. Resources                             |
| 3. Formal Analysis              | 10. Writing - Original Draft Preparation |
| 4. Conceptualization            | 11. Software                             |
| 5. Data Curation                | 12. Supervision                          |
| 6. Writing - Review and Editing | 13. Validation                           |
| 7. Research                     | 14. Visualization                        |

### Acceptance note:

This article was approved by the journal editor, Dr. Natalia Tancredi Cueto, MSc.